

**ISUZU**  
**THE PICK-UP**  
**PROFESSIONALS**

THE AWARD-WINNING ISUZU D-MAX

**V-CROSS**



[isuzu.co.uk](http://isuzu.co.uk)



THE AWARD-WINNING ISUZU D-MAX

# V-CROSS

Providing legendary Isuzu capability and durability, this robust and proven workhorse offers superior levels of comfort and refinement in our most exciting pick-up yet, the Isuzu D-Max V-Cross.

Distinctive styling, class-leading safety and unrivalled off-road performance combine to deliver a pick-up that consistently meets all of life's needs with ease.

A life driven by work, family and adventure demands more, and the Isuzu D-Max V-Cross delivers.





**“It’s got the strength and off-road capability you’d expect” ... “and can swim to its elbows in filth.”**

THE SUN



**FIVE**  
**YEAR**  
125K MILE  
WARRANTY\*

**3.5**  
**TONNE**  
TOWING  
CAPACITY

—OVER—  
**1.0**  
**TONNE**  
PAYLOAD

**164**  
**PS**

**5** YEAR  
UK  
& EU  
ROADSIDE  
ASSISTANCE

**12** YEAR  
ANTI-CORROSION  
WARRANTY

**VAT**  
**BACK**  
QUALIFIED

**NO**  
**SPEED**  
RESTRICTIONS

\*5 year / 125,000 miles (whichever comes first) warranty applies to all new Isuzu D-Max models.



# SMARTER.

Striking good looks and a proven pedigree, the Isuzu D-Max V-Cross is trusted to perform and designed to stand out.





## ASSERTIVE EXTERIOR

Sleek Bi-LED headlights, distinctive gun metal styling and robust 18" alloy wheels provide a commanding road presence.

Loaded with intelligent driver aids, automatic headlights feature high beam assist and automatic windscreen wipers will activate when moisture is detected on the windscreen. Plus, front and rear parking sensors and a reversing camera ensure safe and convenient manoeuvring.

Newly designed side steps and keyless entry afford easy access to the cabin and a tailgate damper ensures a gentle opening action when accessing the load bed.



**“It’s better equipped, smarter to look at, is a more capable work vehicle and is the safest truck in the class.”**

AUTO EXPRESS

# SMARTER.

Plenty of room and loaded with tech, the Isuzu D-Max V-Cross provides outstanding levels of comfort and convenience.







## ELEGANT INTERIOR

Sophisticated leather upholstery and an 8-way electrically adjustable driver's seat with power lumbar support is combined with a height and reach adjustable leather steering wheel to ensure maximum driver comfort.

Dual zone climate control allows the driver and passenger to set different temperatures and entertainment is provided by the 9" touchscreen which features DAB, Bluetooth®, Apple CarPlay™ and Android Auto™.

Flat folding, modular rear seats and a variety of storage compartments mean the spacious cabin can be configured for any adventure.





# STRONGER.

Power and performance that you can rely on, the Isuzu D-Max V-Cross is now even better on and off-road.



## TOWING POWER

The V-Cross is capable of towing up to 3.5 tonnes and is equipped with trailer sway control that uses sensors to detect the onset of trailer swing and reduces vehicle speed if sway is identified.

## DRIVING TORQUE

A diesel engine delivering 164PS and 360Nm of torque is mated to a choice of 6-speed manual or 6-speed automatic transmission.

Refined suspension improves ride and ensures comfort, especially when unladen, without compromising on its carrying capacity of over one tonne payload.



**“This D-Max not only looks and drives better than before, it now features class-leading safety, on trend tech, a far better passenger experience.”**

COMPANY CAR & VAN





# STRONGER.

No road? No problem! When the going gets tough, the Isuzu D-Max V-Cross handles all terrains with proven capability, no matter what the conditions.





## OFF-ROAD CAPABILITY

No adventure is off limits with a 4WD shift-on-the-fly system, rear differential lock and a wading depth of up to 800mm.

## TOUGH PROTECTION

Built on a durable ladder chassis, the V-Cross has additional underbody protection covers to safeguard key components when travelling off-road.

**“The D-Max represents astoundingly good value and will seriously impress off road.”**

AUTOCAR





# SAFER.

Best-in-class safety-features—plus a maximum 5 star NCAP rating—take pick-up safety to a whole new level.







REAR RADAR



BLIND SPOT MONITOR



STEREO CAMERA

## ADVANCED DRIVER ASSIST SYSTEMS (ADAS)

### FORWARD COLLISION WARNING

Monitors the road ahead and alerts the driver of a potential collision.

### AUTONOMOUS EMERGENCY BRAKING

Automatically applies the brakes to either prevent an accident or reduce the severity of an impact depending on speed.

### TRAFFIC SIGN RECOGNITION

Reads standard road signs ahead and displays any change in speed limit on the Multi-Information Display.

### INTELLIGENT SPEED LIMITER

Keeps vehicle speed below the speed limit of the road it is travelling along.

### LANE DEPARTURE WARNING

Alerts the driver if they are about to drift out of their lane.

### LANE DEPARTURE PREVENTION SYSTEM

Adjusts steering direction to help prevent lane departure if the vehicle is about to depart its lane without indicating.

### LANE KEEP ASSIST<sup>1</sup>

Detects lane markings and makes necessary steering adjustment to help keep the vehicle in its lane.

### AT PEDAL MISAPPLICATION MITIGATION<sup>1</sup>

Will suppress engine torque and issue a visual and audible warning if the driver suddenly accelerates in front of an object.

### ADAPTIVE CRUISE CONTROL<sup>1</sup>

Enables the driver to set both the desired speed and the distance to the car in front.

### BLIND SPOT MONITOR

Detects vehicles in the driver's blind spot and alerts the driver via an orange warning light in the door mirror.

### EMERGENCY LANE KEEPING

If there is a vehicle in the driver's blind spot when changing lanes, the system will adjust the steering direction to prevent the lane change and avoid the collision.

### REAR CROSS TRAFFIC ALERT

Detects vehicles approaching from the left or right while reversing out of a parking space.

ADAS are driving support systems which may not operate optimally under all driving conditions or for all objects. The driver is always responsible for safe and attentive driving and observance of traffic regulations. See Owner's Manual for complete details on system operation and limitations. <sup>1</sup>Automatic transmission only.



# EXTERIOR SPECIFICATION.



THE ISUZU D-MAX V-CROSS





Key: ■ Standard □ No Cost Option

## EXTERIOR

## V-CROSS

Bi-LED Headlights	■
LED Daytime Running Lights	■
Automatic Headlights	■
High Beam Assist	■
Automatic Headlight Levelling	■
LED Rear Lights	■
LED Front Fog Lights	■
Rear Fog Lights	■
Automatic Windscreen Wipers with Rain Sensor	■
Heated Rear Screen	■
Gun Metal Radiator Grille	■
Body Coloured Front Bumper	■
Body Coloured Rear Bumper with Integrated Step	■
Gun Metal Side Steps	■
Folding, Heated, Gun Metal Door Mirrors with Side Indicator Repeaters	■
Gun Metal Door Handles	■
Integrated Fuel Filler Cap with AdBlue	■
Tailgate Damper	■

## WHEELS

18" Alloy Wheels - Gun Metal	■
Locking Wheel Nuts	■
Full Size Spare Wheel - Steel	□





# INTERIOR SPECIFICATION.





Key: ■ Standard □ No Cost Option

INTERIOR	V-CROSS
Leather Upholstery <sup>1</sup>	■
8-Way Adjustable Driver's Seat (Electric)	■
Driver's Seat Lumbar Support (Power)	■
Heated Front Seats	■
Front Seatback Map Pockets	■
Flat Folding Rear Seats	■
60/40 Folding Seat Base	■
Under Seat Base Storage	■
Height Adjustable Front Headrests	■
Height Adjustable Rear Headrests	■
Front Centre Armrest	■
Front Cup Holders (Centre Console & Dash - Driver & Passenger Sides)	■
Front Door Pockets with Bottle Holder	■
Rear Centre Armrest with Cup Holders	■
Rear Door Pockets with Bottle Holder	■
Leather Steering Wheel	■
Carpet Floor Trim	■
Driver's Foot Rest	■
V-Cross Branded Carpet Mats	■
ENTERTAINMENT	
9" Multifunction Colour Touchscreen	■
Bluetooth® Connectivity	■
DAB Radio	■
Apple CarPlay™ & Android Auto™	■
CD Player	■
Eight Speakers	■
Front USB Port	■
Rear USB Port	■

<sup>1</sup>Leather and other materials.



# VEHICLE SPECIFICATION

Key: ■ Standard □ No Cost Option

COMFORT & CONVENIENCE	V-CROSS
Remote Control Central Locking	■
Follow Me Home Light	■
Keyless Entry & Push Button Start System	■
Welcome Light	■
Power Windows (Front & Rear) <sup>2</sup>	■
Sun Glass Holder & Overhead Console	■
Map Lights	■
Driver & Passenger Sun Visors with Illuminated Vanity Mirror	■
Auto Dimming Rear View Mirror	■
Height & Reach Adjustable Steering Wheel	■
Steering Wheel Mounted Audio & Cruise Controls	■
12-Volt Power Outlet	■
Gear Shift Indicator (Manual Only)	■
4.2" Multi-Information Display	■
CLIMATE CONTROL	
Dual Zone Climate Control	■
Rear Ventilation Panel	■
ADVANCED DRIVER ASSIST SYSTEMS <sup>3</sup>	
Cruise Control	■
Adaptive Cruise Control (Auto Only)	■
Forward Collision Warning	■
Autonomous Emergency Braking	■
Traffic Sign Recognition	■
Intelligent Speed Limiter <sup>4</sup>	■
Lane Departure Warning & Prevention System	■
Lane Keep Assist (Auto Only)	■
AT Pedal Misapplication Mitigation (Auto Only)	■
Blind Spot Monitor	■
Emergency Lane Keeping	■
Rear Cross Traffic Alert	■

SAFETY & SECURITY	V-CROSS
Front & Rear Parking Sensors	■
Reversing Camera	■
Rear Differential Lock	■
4WD Shift-On-The-Fly	■
Speed-Sensitive Power Steering	■
ESC (Electronic Stability Control)	■
Traction Control	■
Trailer Sway Control	■
ABS (Anti-Lock Braking System)	■
EBD (Electronic Brakeforce Distribution)	■
Brake Assist System	■
Hill Start Assist	■
Hill Descent Control	■
E-Call	■
Multi-Collision Brake	■
Security Etched Glass	■
Insurance Approved Immobiliser	■
Alarm with Deadlock	■
Front, Side, Curtain & Driver Knee SRS Airbags <sup>5</sup>	■
Centre SRS Airbag <sup>5</sup>	■
Passenger Airbag Deactivation Switch	■
Height Adjustable Front Seatbelts with Pretensioner & Load Limiter	■
3 x Three-Point Rear Seatbelts (Side & Centre)	■
ISOFIX Child Seat Anchors with Top Tether Anchors (2 x Rear Side)	■
Rear Door Child Locks	■
Seatbelt Reminder Indicator (All Seating Positions)	■
Door Open Warning Light	■
Stop & Start System <sup>6</sup>	■

<sup>2</sup>Driver side has auto up/down function, with pinch protection and timer. <sup>3</sup>ADAS are driving support systems which may not operate optimally under all driving conditions or for all objects. The driver is always responsible for safe and attentive driving and observance of traffic regulations. See Owner's Manual for complete details on system operation and limitations. <sup>4</sup>Manual & Intelligent Speed Limiter. <sup>5</sup>SRS: Supplemental Restraint System. Must be used in conjunction with seatbelts. <sup>6</sup>According to conditions, the Stop & Start system will automatically stop and restart the engine when the vehicle comes to a standstill to reduce fuel consumption and emissions.





**“V-Cross will easily manage most terrain its owners will throw it at.”**

SUNDAY EXPRESS



# TECHNICAL SPECIFICATION

ENGINE	MANUAL	AUTO
Engine Type	RZ4E	
Fuel Type	Diesel	
Arrangement Cylinders	4, In line	
Firing Order	1-3-4-2	
Bore mm	80.0	
Stroke mm	94.4	
Compression	15.9	
Engine Capacity cm <sup>3</sup>	1898	
Idle Speed	750+/- 25	
Fuel Tank Capacity Litres	76	

GEAR RATIOS		
1	4.942	3.600
2	2.452	2.090
3	1.428	1.488
4	1.000	1.000
5	0.749	0.687
6	0.634	0.580
Reverse	4.597	3.732
Final Drive	4.300	4.300

PERFORMANCE		
Net Power PS @ rpm	164 @ 3600	
Torque Nm @ rpm	360 @ 2000 - 2500	
Maximum Speed (mph)	112	
Acceleration (0-62mph) sec	12.7	13.0

FUEL CONSUMPTION WLTP (MPG) <sup>1</sup>		
Low	27.6	25.1
Mid	36.4	31.4
High	39.4	36.0
Extra-High	30.8	29.0
Combined	33.6	30.7
CO <sub>2</sub> emissions g/km	220	241
Emissions Class	Euro 6D	

<sup>1</sup>MPG figures are EU test figures for comparative purposes and may not reflect real driving results. There is a new WLTP test used for fuel consumption and CO<sub>2</sub> figures. The fuel consumption and CO<sub>2</sub> emissions shown are based on the WLTP testing method. Only compare fuel consumption and CO<sub>2</sub> figures with other vehicles tested to the same technical standard. The fuel consumption you achieve in real life conditions and CO<sub>2</sub> produced will depend upon a number of factors including accessories fitted (post-registration), variations in weather, driving styles and vehicle load etc. <sup>2</sup>Maximum payload capacity as defined by HM Revenue and Customs for VAT purposes. Payload is gross vehicle weight minus kerb weight. Kerb weights quoted are for vehicles with standard specification. Kerb weight and payload may be influenced by badge level, factory options and dealer fitted accessories. It is the responsibility of the vehicle operator to ensure their vehicle is legally compliant for road use.

DIMENSIONS (MM)	MANUAL	AUTO
Length	5265	
Width	1870	
Height	1790	
Front Overhang	890	
Rear Overhang	1250	
Wheelbase	3125	
Track (Front & Rear)	1570	
Ground Clearance (Rear Axle)	235	
Approach Angle (Degrees)	31	
Departure Angle (Degrees)	24	
Ramp Angle (Degrees)	22	

LOAD BED (MM)		
Length	1495	1495
Width	1530	1530
Depth	490	490

WEIGHTS (KG)		
Kerb Weight	2000	2030
Gross Vehicle Weight	3100	3100
Payload <sup>2</sup>	1100	1070
Max Front Axle	1450	1450
Max Rear Axle	1910	1910
Trailer Weight Braked	3500	3500
Trailer Weight Unbraked	750	750
Nose Weight	245	245
Gross Train Weight	6000	6000

WHEELS & TYRES		
Tyres	265/60R18	
Wheels	18x7.5 J	



# VEHICLE DIMENSIONS

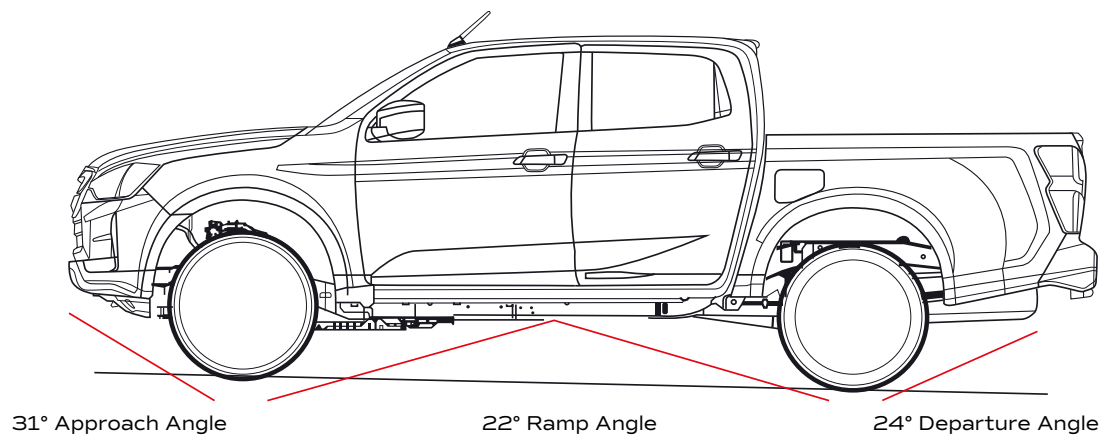
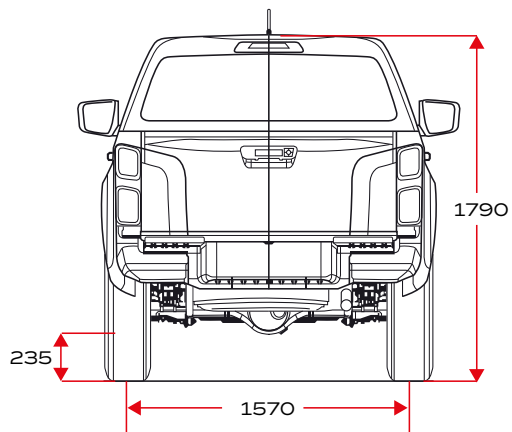
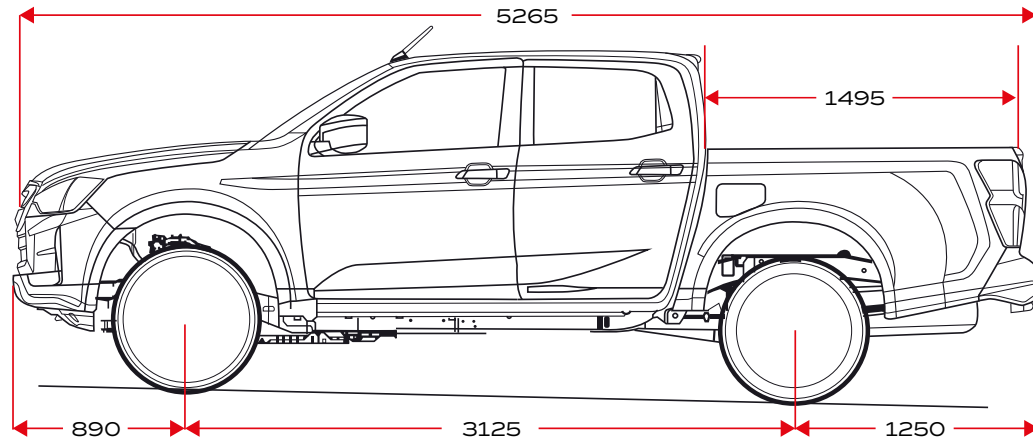
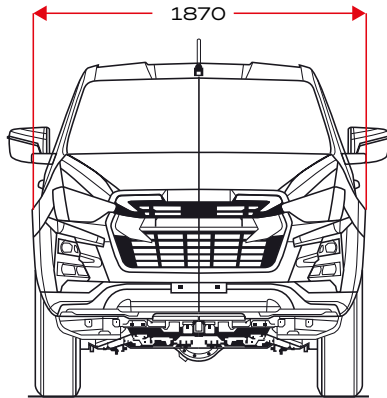



# COLOURS.



**SPLASH WHITE**



**OBSIDIAN GREY**  
MICA



**MERCURY SILVER**  
METALLIC



**ONYX BLACK**  
MICA



**SPINEL RED**  
MICA



**SAPPHIRE BLUE**  
MICA



**VALENCIA ORANGE**  
METALLIC

**PEARL WHITE.**  
EXCLUSIVE  
TO V-CROSS.



**PEARL WHITE**  
PEARLESCENT



**ISUZU**  
**THE PICK-UP**  
**PROFESSIONALS**



**V-CROSS**

[isuzu.co.uk](https://www.isuzu.co.uk)



Isuzu (UK) LTD reserve the right to change specifications and equipment without notice. Features and specification may vary in appearance and/or availability. For full details please contact your local Isuzu dealer or visit [isuzu.co.uk](https://www.isuzu.co.uk)

Part No. IB554